

SPIROPRESS®

Spirotech: accessories, additives and advice

Spirotech designs and produces innovative total solutions for conditioning fluids in HVAC and process systems. Our products and services reduce faults and wear, less maintenance is required, performance is improved and energy consumption is reduced.

Spirotech is deservedly regarded as the only real specialist in the world. Leading manufacturers of system components recommend Spirotech products on account of their high standard of quality and the company's vision on product development and process improvement.

Thanks to a very extensive international network of suppliers, users all over the world enjoy the benefits of our products and services every day.

Spirotech is a Spiro Enterprises company.



Spirotech bv
P.O. Box 207
5700 AE Helmond, The Netherlands
Tel.: +31 (0)492 578 989
Fax: +31 (0)492 541 245
E-mail: info@spirotech.nl
Internet: www.spirotech.com

Spirotech UK Ltd.
P.O. Box 109 Glossop
Derbyshire SK13 1WT
Phone: +44 (0)208 451 3344
Fax: +44 (0)208 451 3366
E-mail: info@spirotech.co.uk
Internet: www.spirotech.co.uk

The diagrams and situations presented in this brochure are only intended to serve as examples. We would be pleased to advise you on any specific situations. Modifications and printing/typographic errors reserved.
©Copyright Spirotech bv. No part of this publication may be used without prior written permission from Spirotech bv.



SPIROPRESS® | VACUUM DEGASSING &
PRESSURISATION SOLUTIONS
FOR HEATING, COOLING
AND PROCESS SYSTEMS



COMMERCIAL | INDUSTRY



SPIROPRESS®

SPIROTECH BENEFITS

The Spirotech approach, combining deaeration and dirt separation along with pressurisation will render the following benefits to all parties involved:-

- A correctly designed system
- Increase System Efficiency
- Dramatically reduce maintenance costs for Pump Seals, Fouling of Control Valves, Blockages in Heat Exchangers.
- Minimal, but annual maintenance of our products
- The 'Risk' is taken away from the designer's and installer's aspect
- The manufacturer (Spirotech UK Ltd) will stand by each and every design
- Trouble free products installed
- Deaerated water increases pump efficiency by reducing power absorbed by up to 30% in certain instances

Introducing SpiroPress Wet systems in perfect balance

In 1968 our founder Frans Roffelsen invented deaeration of wet systems, and since that time the Spirotech mission and vision has been to provide customers with wet systems operating at their optimum efficiency.

By integration of Pressurisation operating alongside our well established deaeration and dirt separation products we can complete the loop of providing the ultimate care of the system, not just for the commissioning phase, but for the lifetime of that system.

Pressurisation, under the product name of SpiroPress provides a full range of products from the most basic system up to virtually any situation within the auspices of the HVAC Industry.

RANGE FOR PRESSURISATION

Spirotech provides a full range of Pressurisation solutions.

On smaller systems with relatively low pressures and volumes, the SpiroPressFill (SPF) range provides pump/fixed diaphragm vessel type pressurisation, with Deaeration and Dirt Separation being provided independently.

In the intermediate range, SpiroPressControl (SPC) is provided. Adopting identical technology for pressurisation, pump/fixed diaphragm vessel, with the added benefit of the pump being used to perform Degassification of the system water. Dirt Separation being provided independently by an in-line unit.

Systems with higher pressures and/or larger system volumes the SpiroPress MaxControl (SPMC) is provided. To accommodate the greater expansion within these systems, pressureless spill-type vessels are provided. Deaeration and Dirt Separation being provided independently.

DESIGN

Undersized Expansion vessels are cause for total breakdown of water quality resulting in corrosion, blockages and fouling.

The design phase of any project is the appropriate time to analyse and built into the system the correct engineered solution to maintain optimal water quality and thus system performance and lifetime.

Spirotech is driven to provide our customers with designs for their specific installations, not just to refer to websites and left to size for themselves. Therefore, all our designs are installation specific for the individual needs and actual requirements, because no two systems are alike.

All information will be collated and the correct solution for the installation proposed.

COMMISSIONING

With the introduction of SpiroVent Deaeration alongside pressurisation, the system will rapidly be totally air free to allow any form of balancing procedure to start within usually 2 to 3 days. So saving valuable time at the critical phase of any installation.

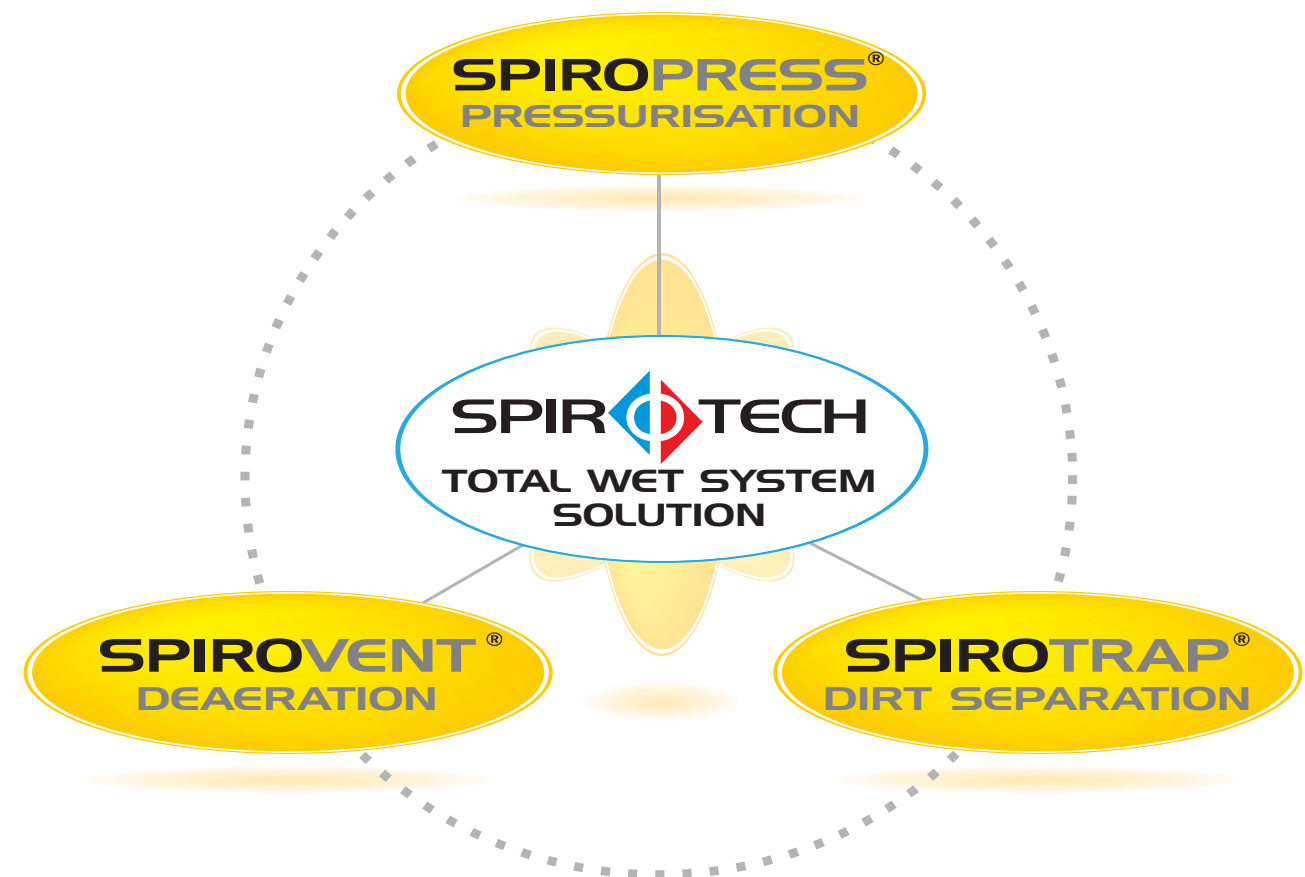

By taking this concern and care to select correctly the customer is dealing with a trustworthy supplier, deep in the knowledge that our R&D Department [TUV approved Test Equipment] provides continual development in the interests of highest quality equipment.

SPIROPRESSurisation for improved system control

Pressurisation is an extremely important part of the system, where all components need to be analysed to create the correct design.

The initial concept of correct pressurisation is that the system water containing water treatment should never be weakened by the introduction of untreated water by the pressurisation pump, in other words the main criteria is to ensure that the provided expansion vessel(s) are so sized that all the expanded water is taken up by the vessel(s).

If the pressurisation pump does start up it should only be due to an emergency, a leak or partial drain down & refill under normal maintenance with water treatment being sampled and added to as necessary.

To provide improved system control Pressurisation all the following aspects combine to enable the correct design

SYSTEM DETAILS

The maximum operating temperature needs to be known, static head from the foot of the expansion vessel(s) to the top level of the circulating system, system KW rating, power plant total KW rating, glycol content (if applied), header size, system flow rate, etc., all to evaluate the most variable item – the actual total system volume to enable the expansion vessel volume to be calculated.

CALCULATING EXPANSION VESSEL VOLUME

It can be very difficult to calculate the actual system volume and a 'rule of thumb' gained through experience and historic evaluations more than likely has to be employed in the first instance.

The components included in the system need to be known as they effect the system volume. There are universally accepted volume rates (in litres/KW) within the industry.

The KW rating is based upon the maximum system rating and not particularly the Boiler/Chiller total ratings.

Plant remote from buildings, or systems feeding multiple buildings need to be considered when calculating vessel volumes and some extra capacity needs to be allowed for in these cases.

The final total Vessel Volume should be such that all aspects are considered on a project by project basis, plus any additional allowances ending up with the Vessel Volume around 5% to 10% greater than that calculated.

VESSEL ACCEPTANCE & TYPES OF EXPANSION VESSEL

Another aspect of the 'grey art' is the vessel acceptance and our range of pressurisation units consists of 'fixed diaphragm' and 'pressureless' vessels.

FIXED DIAPHRAGM VESSELS

Generally these vessels provide an acceptance of usually 30% or less, pressure dependent.

There is a high quality butyl diaphragm with 'air' on one side of the diaphragm and system water on the other side.

PRESSURELESS VESSELS (SPILL TYPE SYSTEMS)

These vessels have a high quality butyl bladder that is contained within the expansion vessel and have an acceptance of 70%

MAINTENANCE OF THE FIXED DIAPHRAGM EXPANSION VESSEL(S)

Once installed, annual maintenance of the whole pressurisation equipment must always be rigidly enforced. The vessel requires the checking of the air pressure at least annually. This is achieved by isolating from the system, draining down, checking cold fill pressure and air added as required. Larger vessels would benefit from more frequent checks.

THE PRESSURISATION PUMP

In a well designed pressurisation system a single, high quality, pump is more than adequate. To prevent the pump seizing up, the controls are such that the pump should be operated at least twice a week.

CONNECTING THE VESSEL(S) TO THE SYSTEM

The interconnecting pipe from the system to the vessel(s) should be correctly sized to negate a pressure build up on warming up leading to water ejected through the safety valve which needs make-up water to replenish on cooling down.

CONTROLS

Controls are such that there are BMS connections within the Pressurisation Control Panel, which provides an alarm within the BMS whenever a fault has occurred, and the operator should then go to the Pressurisation Control Panel to discover the fault reason and rectify accordingly.

Any requirement for interlocks on the main plant items should be provided by the main plant item manufacturer.

IN SUMMARY

The above-mentioned represent some of the main aspects of Spirotech's vast knowhow and experience gathered throughout years of working in the field of maintaining system water quality. Incorporated in our SpiroPress design, hardware and philosophy, they ensure ultimate system control to the end user.

SpiroPress Control

OPERATION/CONTROL

The SpiroVent Superior Pressure Differential Deaerator (Vacuum Degasser) lends itself quite simply to this application when supplied with the required Expansion Vessel(s) and so provide the SpiroVent very deep level of deaeration coupled up with the controls to provide built-in Pressurisation.

The unit is provided with pump, deaeration vessel, system pressure sensor, deaeration solenoid valve & cold water make-up solenoid valve, as Fig1

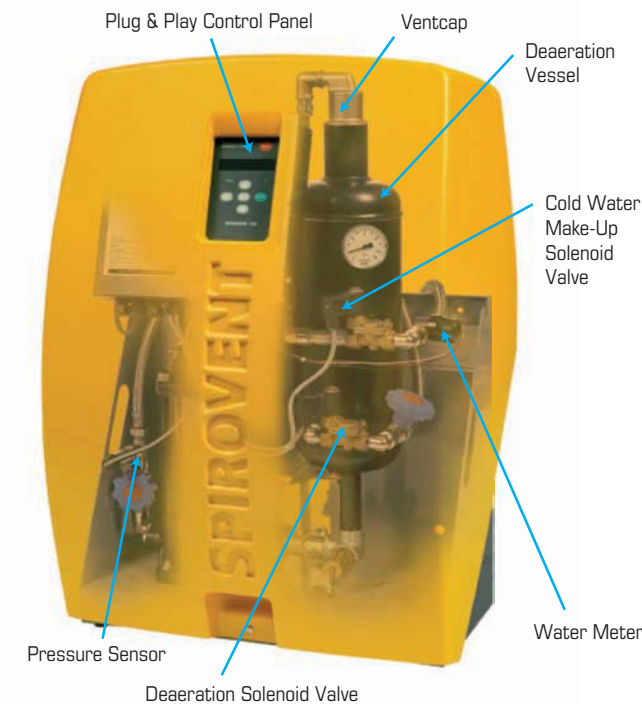

Upon start up, the Deaeration Solenoid Valve alternates between the "Deaeration" and "Flushing" phases until the "Smart Switch", located within the control panel, senses complete deaeration then switches the unit off automatically.

If the System Pressure Sensor detects a low system pressure, then priority of control is automatically diverted to the Cold Water Make-Up Solenoid Valve, with the Deaeration Solenoid Valve on standby.

Once the Pressure Sensor is satisfied, the Cold Water Make-Up Solenoid Valve reverts to the standby mode with priority transferred back to the Deaeration Solenoid Valve.

The Customer to provide 22mm Cold Water Make-Up connection at minimum 1bar.

Start up for deaeration can then be programmed in to suit site conditions, but the Pressurisation control is governed by Pressure Sensor activation, which is constantly 'on line'.

Type	S4R	S6R	S10R	S16R
Max. system volume (m³)	25	300	300	300
System pressure (bar)	1 - 4.5	1 - 6	5 - 10	9 - 16
Temperature of system fluid (°C)	0 - 90	0 - 90	0 - 90	0 - 90
Fluid treated (degassed) (l/h)	70	1,000	1,000	1,000
Refill volume (l/h) 1)	50	450	500	500
Ambient temperature (°C)	0 - 40	0 - 40	0 - 40	0 - 40
Dimensions (HxWxD)	490x340x340	680x590x350	1300x680x350	1300x680x350
Empty weight (kg)	17	59	79	89
Supply voltage (V)	230	230	3 x 400	3 x 400
Power consumption (watt)	100	800	1150	2250
Degree of protection (IP)	X4D	X4D	X4D	X4D
Article number	MA04R	MA06R	MA10R	MA16R

1) An approved non-return protective device (G¾" male) is available as an option.

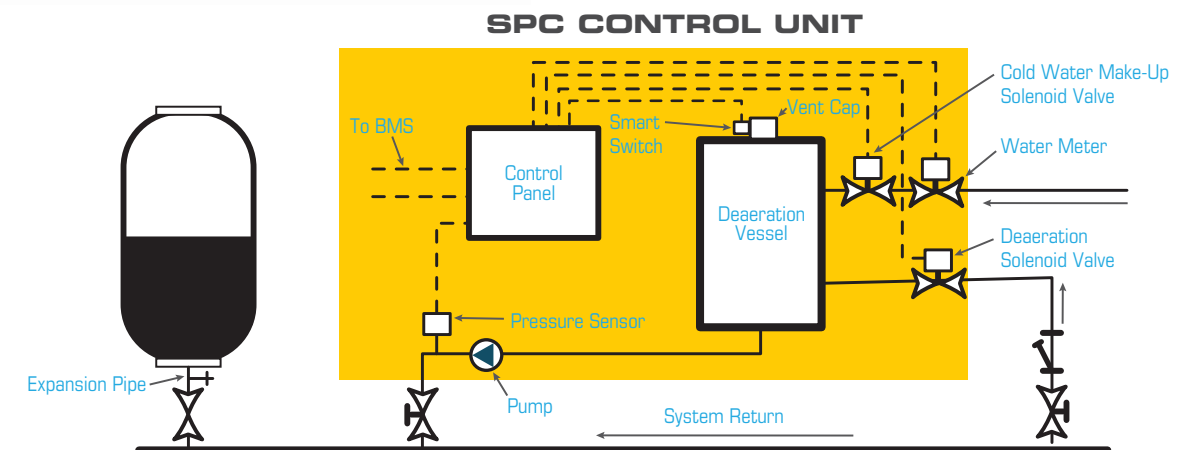

EXPANSION VESSEL CONNECTION TO SYSTEM

The Expansion Pipe connecting the system to the Expansion Vessel must accept the water velocity created due to the expansion without creating any back pressure in the system, with bends being used and not elbows.

A lockshield valve should be incorporated for isolation purposes. This

should always be open except when draining the vessel of water for routine checking of the air pressure for maintenance purposes. A drain lockshield valve should also be fitted to this pipe. The Expansion Pipe should be as short as possible, if longer than 5 metres the next pipe size up should be used.

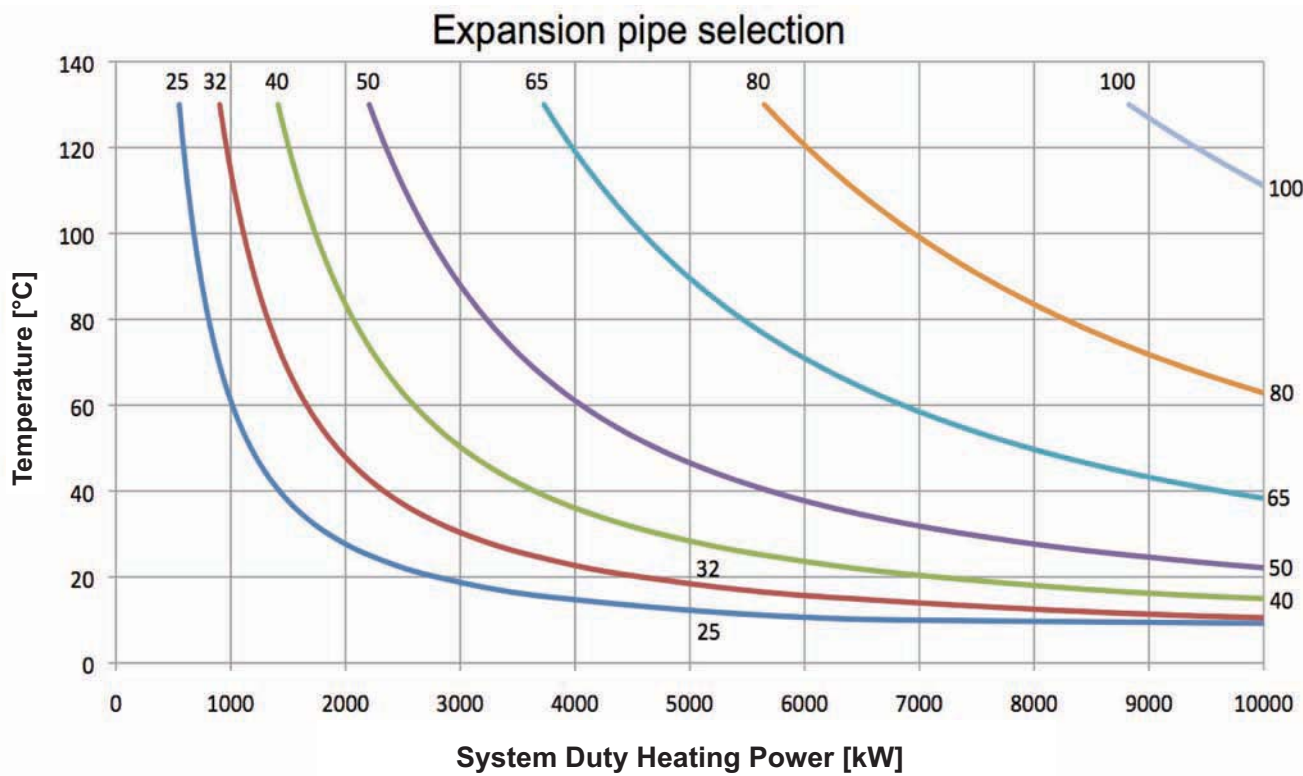

EXPANSION VESSEL(S) - FIXED DIAPHRAGM TYPE

The Expansion Vessel(s) employed are of the 'Fixed Diaphragm' type. The air pressure requires adjustment during commissioning to set at the 'Cold Fill' pressure, usually Static Head + 0.5bar. The membrane is high quality butyl with a minimum 10 year life expectancy and suitable for system maximum operating temperatures as listed. A Buffer Vessel being required if the maximum operating temperature is exceeded.

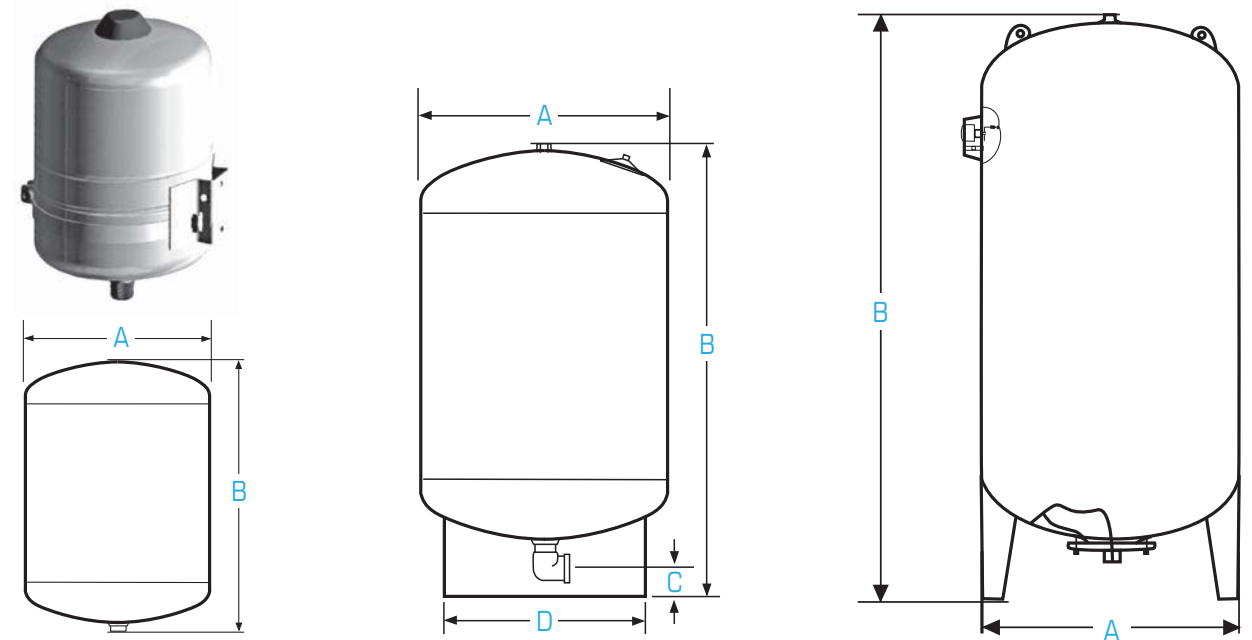
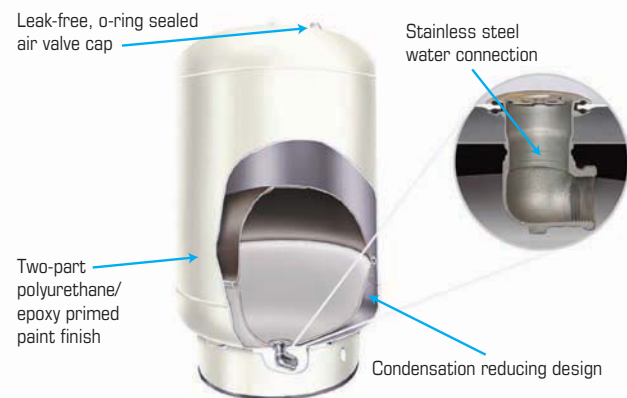

EV0002F/EV0150F RANGE

EV0170F/EV0450F RANGE

EV0750F/EV1000F RANGE

Article No.	Model	Operating Pressure (bar)	Maximum Operating Temp [°C]	Nominal Volume (litre)	Conn'n Size (bsp)	Dia A (cm)	Height B (cm)	Height C (cm)	Dia of Base D (cm)	Weight (Kg)	Pre-charge (bar)
* EV0002F	HW2	10	99°C	2	3/4"	12.7	18.3	N/A	N/A	1	0.7
* EV0008F	HW8	10	99°C	8	3/4"	20.3	31.7	N/A	N/A	2.6	0.7
* EV0012F	HW12	10	99°C	12	3/4"	24.4	36.6	N/A	N/A	3.2	0.7
* EV0018F	HW18	10	99°C	18	3/4"	27.9	36.8	N/A	N/A	4.3	0.7
* EV0024F	HW24	10	99°C	24	3/4"	29.2	44.4	N/A	N/A	5.6	0.7
* EV0035F	HW35	10	99°C	35	3/4"	31.8	48.1	N/A	N/A	7	1
* EV0060F	HW60V	10	99°C	60	3/4"	38.8	62.6	N/A	N/A	12.3	1.5
EV0080F	HW80V	10	99°C	80	3/4"	38.8	79	N/A	N/A	16.7	1.5
EV0100F	HW100V	10	99°C	100	1"	43	80.4	N/A	N/A	18.9	1.5
EV0150F	HW150V	10	99°C	150	1"	43	107	N/A	N/A	26	1.5
EV0170F	GC170	10	90°C	170	1 1/4"	53.3	93.9	5.59	43.1	29.9	1.4
EV0240F	GC240	10	90°C	240	1 1/4"	53.3	121.2	5.59	43.1	36.47	1.4
EV0310F	GC310	10	90°C	310	1 1/4"	53.3	150	5.59	43.1	45.4	1.4
EV0450F	GC450	10	90°C	450	1 1/4"	66	152.9	5.59	54	69.31	1.4
** EV0750F	SF750	10	99°C	750	2"	74	195	N/A	N/A	110	4
** EV1000F	SF1000	10	99°C	1,000	2"	80	220	N/A	N/A	165	4

* All vessels are pipe mounted or can be supplied with Wall Bracket

** Vessels have built-in pressure gauge on air side

Vessels finished Silver or Almond by two part polyurethane, epoxy primed paint finish

Vessels manufactured to ISO-9001, Gost and CE/PED Approved

Air chamber sealed with brass air valve and O-ring sealed air cap

SpiroPress MaxControl

The SpiroPressMaxControl (SPMC) is a 'spill' type of pressurisation unit using a pressureless vessel as opposed to the fixed diaphragm type applied to SpiroPressControl (SPC). The immediate benefit is that the vessel acceptance of SPMC is much greater, hence fewer expansion vessels are required.

The operation of the unit is also totally different from SpiroPressControl (SPC).

OPERATION

As the system warms up, the Pressure Maintaining Valve allows water to pass through into the pressureless Expansion Vessel Bladder. The Bladder is provided with a Safety Valve set at 0.5bar providing no contamination of the stored water with the atmosphere. There will never be any build up of pressure as the air space side between the Bladder and the vessel is vented to atmosphere.

The Expansion Vessel acceptance is conservatively controlled at 70%.

When the system is cooling down, the System Pressure Sensor initiates the pump that runs for a preset time period which satisfies the System Pressure Sensor. If there is a further initiation involved, the process is repeated until the System Pressure Sensor is finally satisfied. By implementing time run for the pump, external effects of system pressure fluctuations are eliminated.

The setting of the System Pressure Sensor is normally set to create an overpressure at the top of the building, with the Pressure Maintaining Valve being manually adjusted to suit the desired requirements of the system.

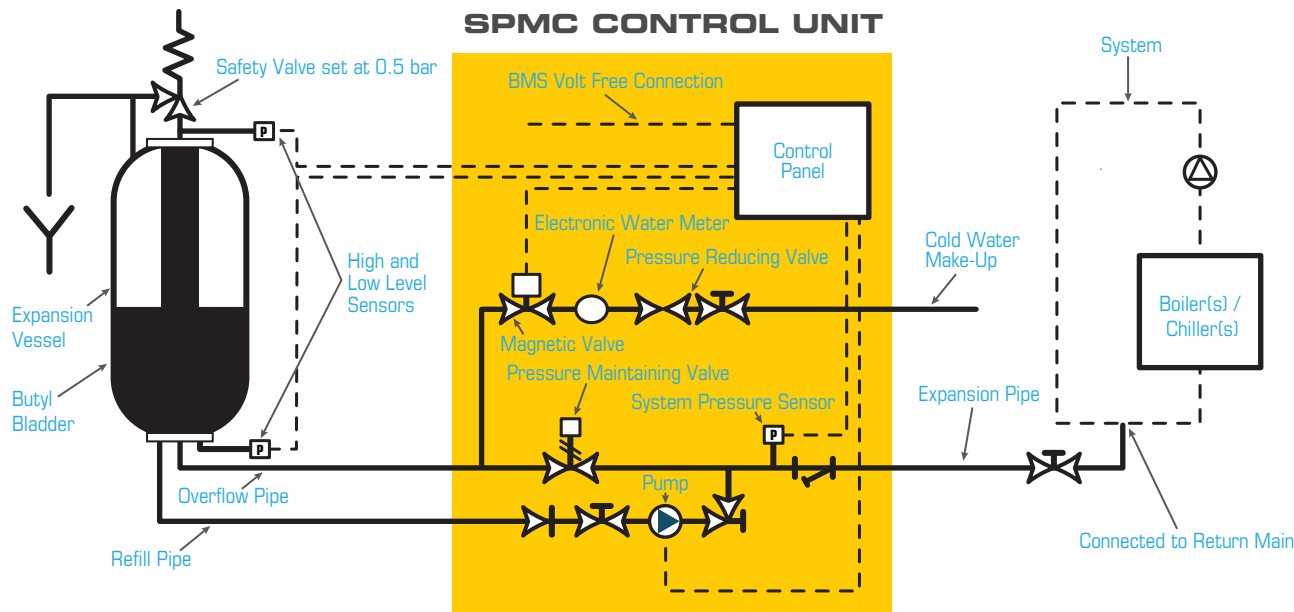

STM CONTROL UNIT

The STM Control Unit is built in accordance with DIN4751 resp. SWKI 93.1.

The standard STM is for single pump operation, but a twin pump Control Unit (STMZ) can be supplied to provide 100% standby.

The STM is fully pre-wired and piped complete with pump, pressure maintaining valve, system pressure sensor and microprocessor control unit.

Built into the STM is the Cold Water Make Up arrangement as the schematic. An integrated water meter totals up all make up water injected that can be read through the control panel readout.

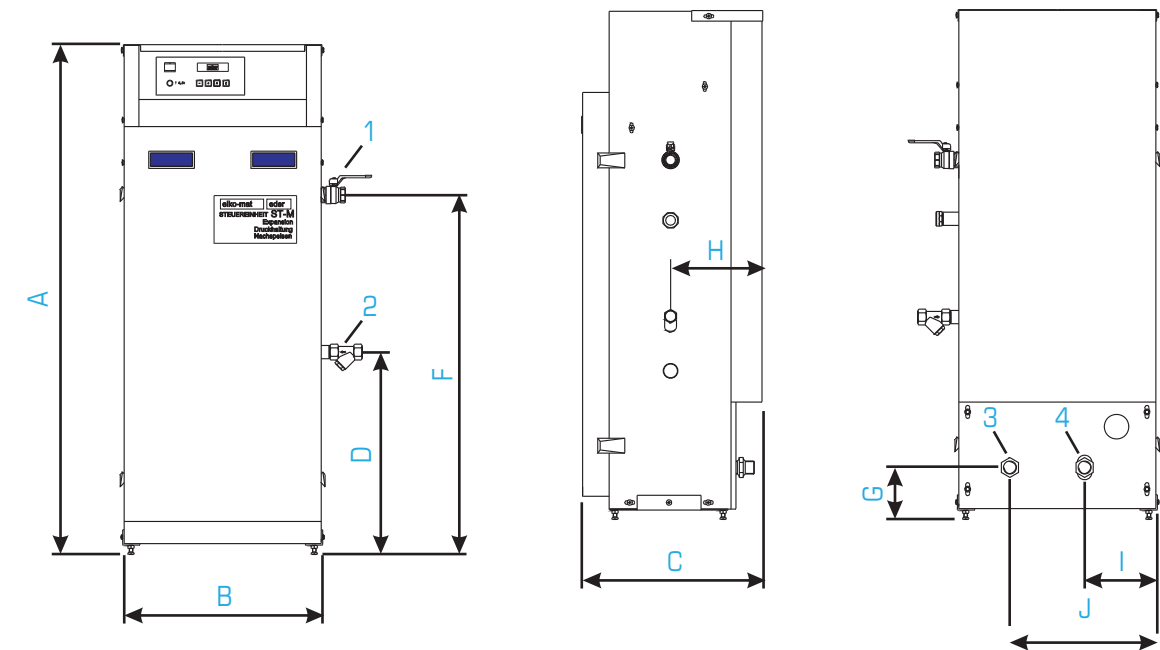

All dimensions in mm - 1 cold water make-up. 2 expansion pipe. 3 overflow pipe. 4 refill pipe.

Type	A	B	C	D	E	F	G	H	I	J	1	2	3	4
ST-M1	1035	420	370	415	610	730	105	185	145	300	1/2"	3/4"	1"	1"
ST-M2	1035	610	610	340	525	385	115	180	340	505	1/2"	1"	1"	1"
ST-M3	1035	610	610	340	525	385	115	180	340	505	1/2"	1"	1"	1"
ST-M4	1035	760	710	400	670	385	115	172	400	598	1/2"	1 1/2"	1 1/2"	1 1/4"
ST-M5	1035	760	710	400	670	385	115	172	400	598	1/2"	1 1/2"	1 1/2"	1 1/4"
ST-M6	1035	760	710	400	670	385	115	172	400	598	1/2"	1 1/2"	1 1/2"	1 1/4"
ST-M7	1035	760	710	400	670	385	115	172	400	598	1/2"	1 1/2"	1 1/2"	1 1/4"
ST-M8	1235	760	710	400	670	385	135	172	400	598	1/2"	1 1/2"	1 1/2"	1 1/4"
ST-M8.1	1235	760	710	400	670	385	135	172	400	598	1/2"	1 1/2"	1 1/2"	1 1/4"

EXPANSION PIPE FROM SYSTEM TO STM CONTROL UNIT

(as the SPC system description on page 6).

PRIMARY EXPANSION VESSEL (EPR) - SPILL TYPE

The Primary EPR Expansion Vessel is built in accordance with DIN4751 resp. SWKI 93.1. The vessel Bladder is from high quality Butyl and is capable of withstanding temperatures up to 90°C, and systems with a maximum Glycol content of 35%. EPR vessels are available in sizes 200 litre to 1,000 litre capacities.

Integrated level switches are provided that controls the Pump and Cold Water Make-Up, fitted with 6m connection cables as standard with plug for STM Control Unit. The actual vessel contents are displayed on the control panel. If longer connection cables are required then this must be stated before manufacture. A low level control ensures that the pump never runs dry.

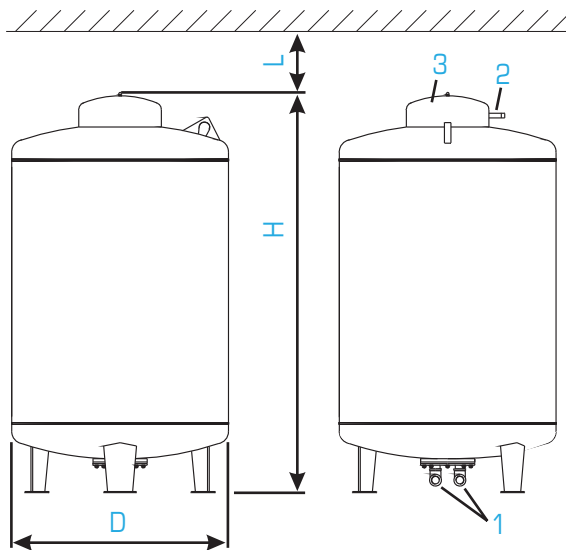

SECONDARY EXPANSION VESSEL (EPRS)

When Secondary Vessels (EPRS) are required, they are identical to the Primary Vessel (EPR) but without the Integrated Level Switches and should be piped in accordance with the three vessel example below.

all dimensions in mm

Primary Vessel	Secondary Vessel	D	H	1	2	3	L
EP0200R	EP0200RS	500	1375	1"	½"	½"	500
EP0300R	EP0300RS	600	1450	1"	½"	½"	500
EP0500R	EP0500RS	600	2160	1"	½"	½"	500
EP0800R	EP0800RS	800	2000	1"	½"	½"	500
EP1000R	EP1000RS	900	2000	1"	½"	½"	500
EP1500R	EP1500RS	1050	2150	1¼"	1¼"	½"	500
EP2000R	EP2000RS	1200	2200	1¼"	1¼"	½"	500
EP2500R	EP2500RS	1050	3150	1¼"	1¼"	¾"	700
EP3000R	EP3000RS	1200	3200	1¼"	1¼"	¾"	700
EP4000R	EP4000RS	1400	3400	1½"	1½"	¾"	1000
EP5000R	EP5000RS	1500	3450	1½"	1½"	¾"	1000
EPX100R	EPX100RS	1700	5600	2"	2"	¾"	1000

- 1 Refill and overflow pipe
- 2 Safety valve drain connection
- 3 Gas-sided connection under hood
- L Minimum free space above container

HYDRAULIC PIPES BETWEEN STM CONTROL UNIT & VESSELS

The overflow and refill pipes are to be sized to suit the storage capacity of the vessel(s) as tabulated in the table. The Expansion Pipe should be as short as possible, if longer than 5 metres the next pipe size up should be used.

All valves should be lockshield type, with lockshield drain valves for maintenance purposes.

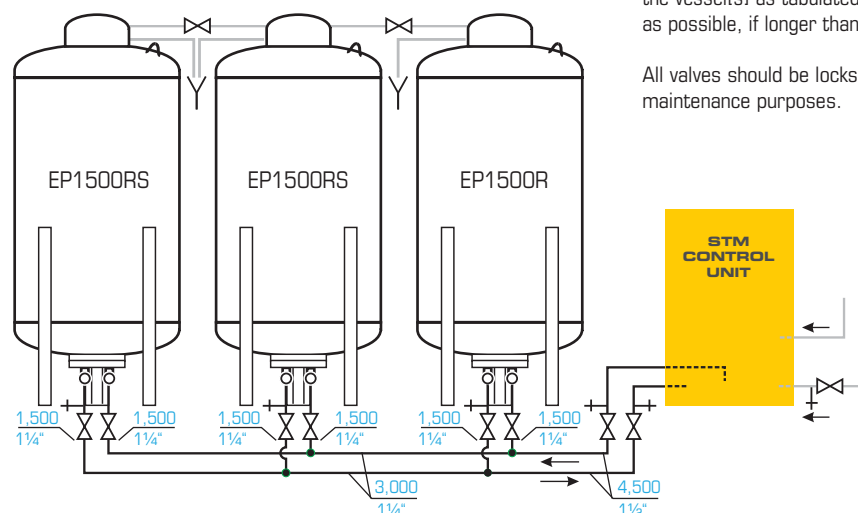

connected vessel volume [litres]	refill pipe size[*]	overflow pipe size[*]
upto 1,000	1"	1"
upto 3,000	1¼"	1¼"
upto 5,000	1½"	1½"
upto 10,000	2"	2"

Sustainability achieved with Spirotech's collaboration

Prolongation claims and costs during commissioning are avoided

- Initial expensive flushing, draining and re-filling system with water treatment protected
- Future drain down and re-fill becomes automatic saves expensive labour costs
- Water Treatment regime protected with minimal future additions required
- Prevents blockages of Heat Exchangers
- Reduces wear on pump seals
- Reduces/eliminates fouling of automatic valve seats
- Fewer Pressurisation Pump starts due to correctly sized Expansion Vessel
- System Deaeration reduces pump power absorbed by up to 30%
- System cleanliness reduces need for re-flushing in future years
- System functions as designed so eliminates cold areas in the building – energy efficiency increased

All of the above points lead to Spirotech's system designs bringing benefit to everyone involved, from specifier to the end user. The Graph illustrates the gains for all parties involved - Everyone's a winner.

